

KOM300
Industrial Ethernet to Fiber Media
Converter

User's Manual

KYLAND Technology Co., Ltd.

Content

CHAPTER 1 PRODUCT OVERVIEW -----	2
CHAPTER 2 MAIN TECHNICAL PARAMETERS--	3
CHAPTER 3 PRODUCTION DESCRIPTION -----	4
1. KOM300 SERIES PRODUCTS LIST -----	4
2. THE FRONT PANEL OF KOM300 MEDIA CONVERTER -----	5
3. INSTRUCTION FOR ETHERNET INTERFACE WIRING -----	6
4. KOM300 GROUNDING -----	7
CHAPTER 4 PRODUCT APPLICATIONS -----	10

Chapter 1 Product Overview

KOM300 Ethernet to fiber media converter is industrial hardened and specially designed to operate reliably in electrically harsh and climatically demanding environments. KOM300 meets the requirements of the most strict international EMI and environmental standards for use in electric utility substations and factory floor applications. Its features are as below:

1. 10/100 Base-TX to 100Base-FX media converter, supporting single mode fiber or multi-mode fiber
2. Complying with IEEE802.3 and IEEE802.3U standards
3. 100M wire speed store and forward
4. 1K MAC address table, 1M buffer memory
5. Easy installation and operation, plug and play
6. Power supply indicator, connection state indicator
7. DIN rail installation, rack bracket for rack mounting installation

Chapter 2 Main Technical Parameters

1. Electrical characteristics	IEEE802.3 and IEEE802.3U standards	
2. Physical interface	RJ45 shielded	
3. Optical transmission distance	Multimode 2~5km, Single-mode 40/80km	
4. Connector	FC/SC/ST	
5. Power supply	24VDC (12~36VDC), 48VDC (36~72VDC), 110VDC (72~144VD), 110VAC/220VAC/220VDC (85~265VAC/120~370VDC)	
6. Input power	<3W	
7. Relative humidity	0-95% (non-condensing)	
8. Optical Power Output	>-13dbm (single mode system)	>-20dbm (multi-mode system)
9. Receiving sensitivity	<-28dbm (single mode system)	<-35dbm (multi-mode system)
10. Working temperature	-40 °C ~+85 °C	
11. Storage temperature	-40 °C ~+85 °C	
12. Mechanical dimension	36mm x 100mm x 75mm (W x H x D)	

Chapter 3 Production Description

1. KOM300 series products list

Model	Description
KOM300-S	2 × 10/100Base-T/TX, RJ45 ports 1 × 100Base-FX, single mode, half duplex port
KOM300-M	2 × 10/100Base-T/TX, RJ45 ports 1 × 100Base-FX, multimode, half duplex port
KOM300-SD	2 × 10/100Base-T/TX, RJ45 ports 1×100Base-FX, single mode, single fiber, bi-directional, half duplex port
KOM300F-S	2 × 10/100Base-T/TX, RJ45 ports 1×100Base-FX, single mode, full duplex port
KOM300F-M	2 × 10/100Base-T/TX, RJ45 ports 1×100Base-FX, multimode, full duplex port
KOM300F-SD	2 × 10/100Base-T/TX, RJ45 ports 1×100Base-FX, single mode, single fiber, bi-directional, full duplex port
KOM300BA-S	2 × 10/100Base-T/TX, RJ45 ports 1×100Base-FX, single mode, full duplex port Intrinsic safety
KOM300BA-M	2 × 10/100Base-T/TX, RJ45 ports 1×100Base-FX, multimode, full duplex port Intrinsic safety
KOM300BA-SD	2 × 10/100Base-T/TX, RJ45 ports 1×100Base-FX, single mode, single fiber, bi-directional, full duplex port Intrinsic safety

2. The front panel of KOM300 media converter

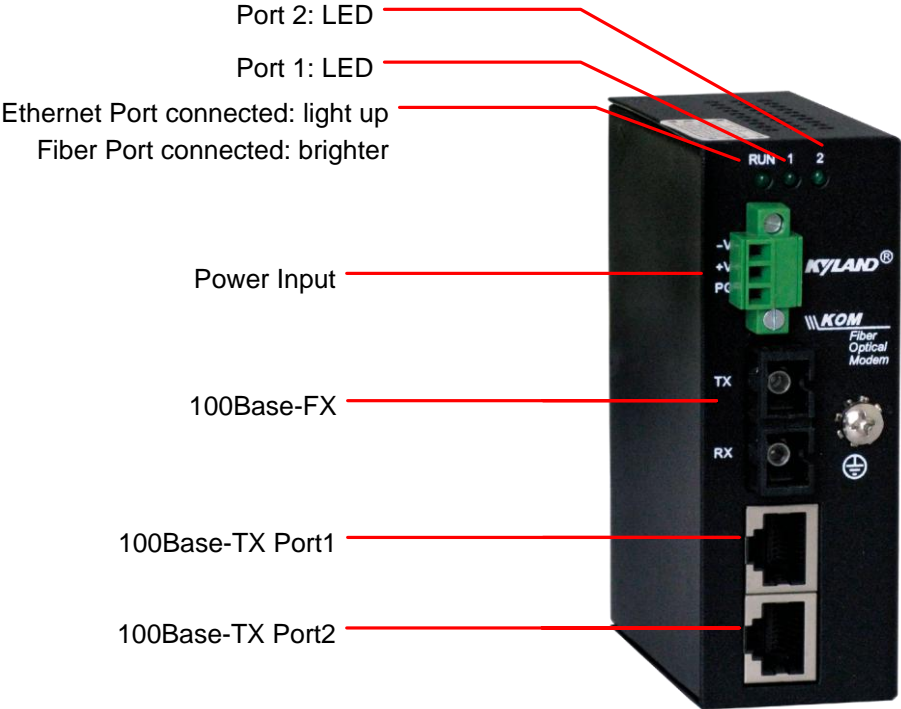
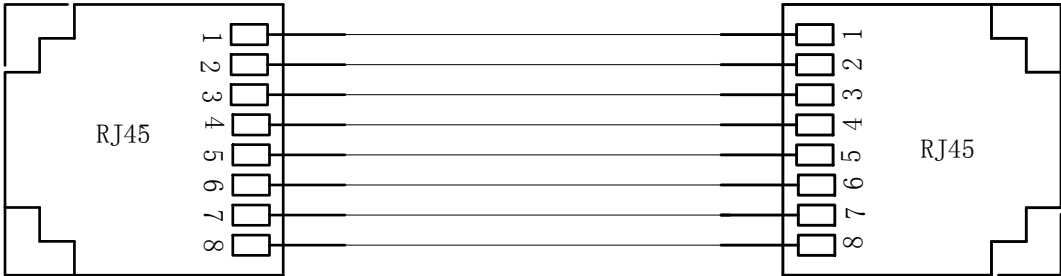

Figure1-Front Pannel

3. Instruction for Ethernet interface wiring

Definition of straight-through cable from RJ45 (8-pin) to RJ45 (8-pin)



The connection sequence is in turn: Orange-white, Orange, Green-white, Blue, Blue-white, Green, Brown-white and Brown

Figure2-Straight through Connection

Definition of Cross-over cable from RJ45 (8-pin) to RJ45 (8-pin)

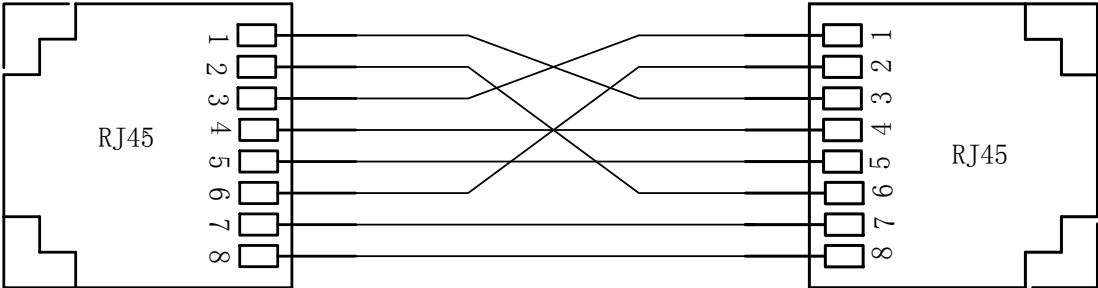

The connection sequence is in turn: Orange-white, Orange, Green-white, Blue, Blue-white, Green, Brown-white and Brown
Green-white, Green, Orange-white, Blue, Blue-white, Orange, Brown-white and Brown

Figure3-Cross over Connection

4. KOM300 Grounding

The device grounding: please ground the Power grounding terminal (PG) and the Casing grounding terminal, showing as Figure 7.

Grounding wires: The section should not be less than 2.5mm^2 , grounding resistance $<5\Omega$, copper core.

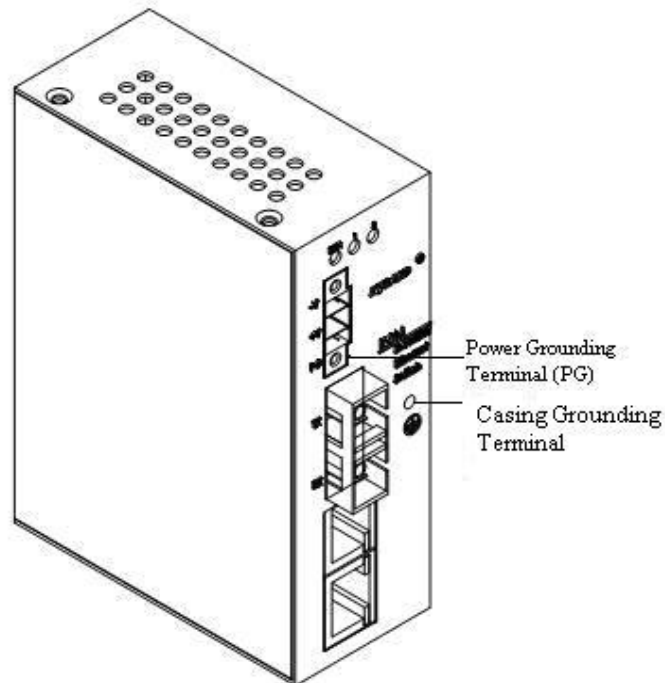

Figure 4: Device grounding

Grounding method:

1. Casing grounding steps are as follows, as Figure 5-a:
 - a. Connect one terminal of grounding wire with the cold-pressing terminal
 - b. Use a grounding screw to fix the cold-pressing terminal to the casing grounding hole
 - c. Ground the other terminal of grounding wire
2. Power grounding steps are as follows, as Figure 5-b:
 - a. Strip 5mm-long sheath from grounding wires and twist the bare copper wires together into a bundle;
 - b. Use a 2.5mm one-slot screwdriver to unscrew the "grounding wires locking screw", insert the grounding wires into the hole at the terminal tail, and screw down the "grounding wires locking screw".
 - c. Ground the other terminal of grounding wires

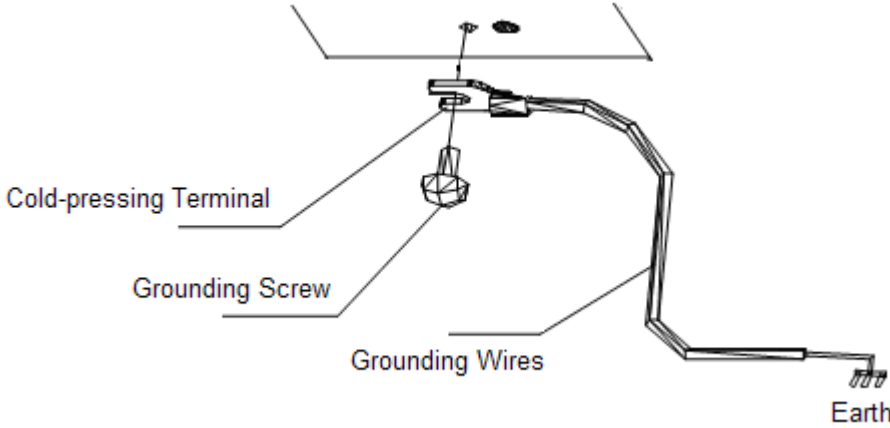

Figure5-a

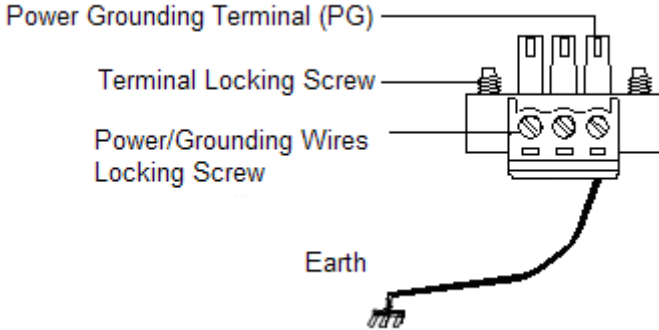

Figure5-b

5. Hardware installation

For most industrial applications, 35mm standard DIN-Rail installation is very convenient. The DIN-Rail connector has been fixed in the rear panel of KOM300. Figure 6 shows the dimension of DIN-rail installation.

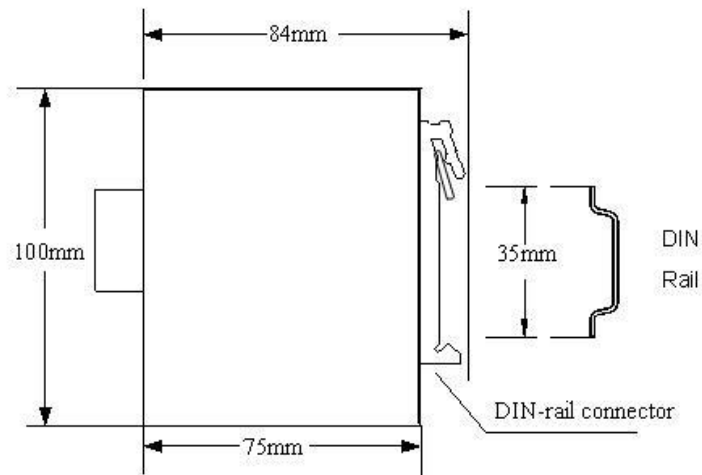

Figure 6 Dimension diagram of DIN-rail installation

1. Before installation, make sure that the DIN-Rail is fixed well;
2. Insert the bottom of KOM300 into the DIN-Rail slot, and turn the equipment as figure 7-a
3. As Figure 7-b, put the DIN-Rail into slot, and make sure the device is completely fixed on the DIN-Rail.

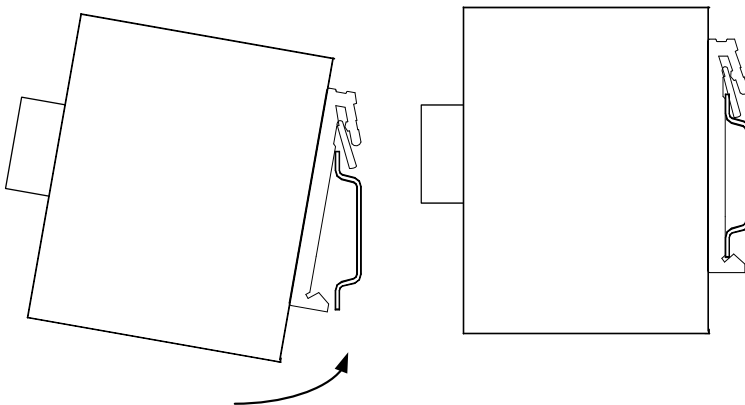

Figure 7-a

Figure 7-b

Figure 7 Install KOM300 into Rail

Chapter 4 Product Applications

KOM300 support point to point networking, as Figure 8:

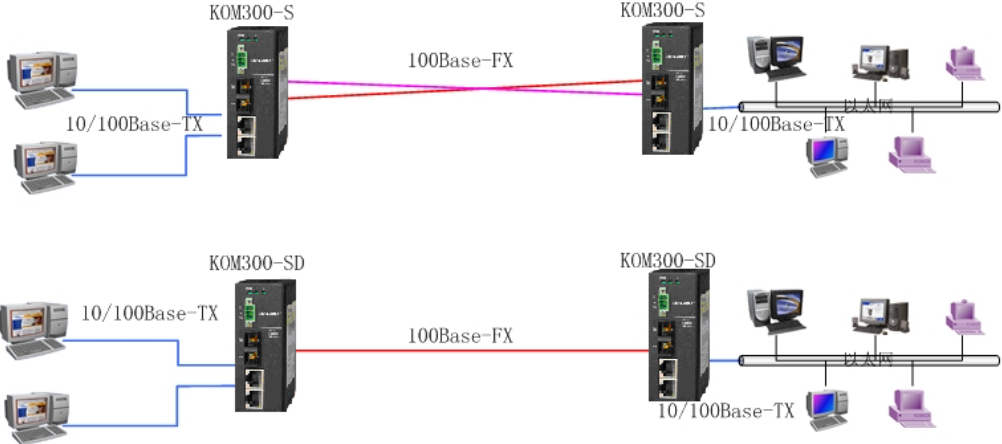

KYLAND

KYLAND Technology CO., LTD.

Address: Chongxin Creative Building, Shixing East Street
18#, Shijingshan District, Beijing, China

TEL: +86-10-88798888

FAX: +86-10-88796678

P.C: 100041

<http://www.kyland.cn>

E-mail: service@kyland.com.cn

Version: V.3 July, 2009

No.: 27030008-3.0